

# PERMCO

# T3.5 IGNIS

高压大排量滑动轴承齿轮泵齿轮马达

HIGH PRESSURE LARGE DISPLACEMENT SLEEVE BUSHING PUMPS AND MOTORS

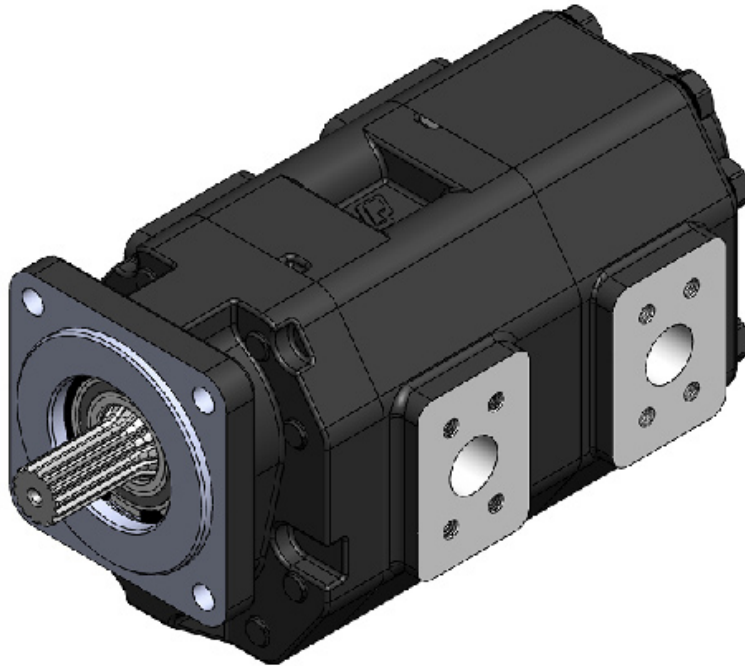

齿轮泵及齿轮马达特点

GEAR PUMP AND MOTOR FEATURES

### 特点

- 本系列最高压力可达30MPa
- 排量从71.5至178.8ml/r
- 两体式设计，结构更加紧凑
- 行业领先的产品性能，提供极高可靠性和更长工作寿命
- 独有专利技术的结构设计，带来低于行业标准的噪音
- 国际化先进试验及检验标准，严格控制产品质量，100%出厂检验
- 泵和马达均有多种联接形式，联接尺寸符合SAE标准
- 可按用户要求设计成单联泵和多联泵

### FEATURES

- Maximum pressure up to 4350 PSI
- Cubic inch displacement from 4.36 through 10.9
- Split in two construction, more compact structure
- Unique and patented structural design plan, leads to lower noise below industry standards
- High strength alloy steel gear shafts greatly advanced the operating pressure grade
- Strictly check product quality with international advanced test standard inspection standard 100% factory inspection
- A wide range of porting, mounting and shaft options available for SAE and European standards
- Customized single and multiple unit options available



## The Sensible Choice

# T3.5系列尺寸数据 (mm/in) DIMENSIONAL DATA (mm/in)

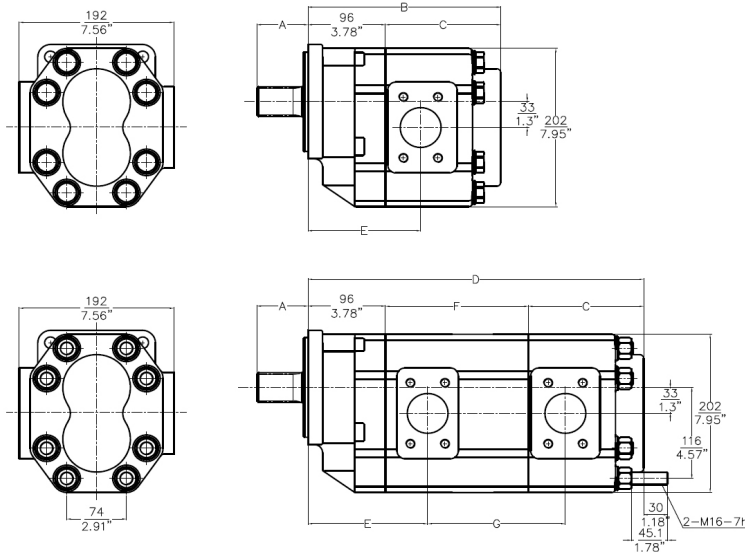

- A. SAE "C" shaft shown, other shafts available  
图示为SAE "C"轴伸, 轴伸型式有多种选择
- B. 7.03" plus gear width  
178.6 mm 加齿轮宽度
- C. 3.25" plus gear width  
82.6 mm 加齿轮宽度
- D. 11.74" plus total gear width  
298.2 mm 加总齿轮宽度
- E. 3.78" plus oil port position  
96 mm 加油口位置尺寸
- F. 4.71" plus gear width  
119.6 mm 加齿轮宽度

## 性能 PERFORMANCE

## 齿轮泵 Gear Pumps

Displacement 排量 ml/rev	Gear Width 齿宽 Inch 英寸	Rated Pressure 额定压力 MPa	Max Pressure 最高压力 MPa	Working Speed RPM 工作转速 转/分		Input Power 输入功率 KW
				Max 最高	Min 最低	
71.5	1	25	30	2200	600	72.8
80.5	1-1/8	25	30	2200	600	82.0
89.4	1-1/4	25	30	2200	600	91.1
98.3	1-3/8	25	30	2200	600	100.2
107.3	1-1/2	25	30	2200	600	109.3
116.2	1-5/8	25	30	2200	600	118.4
125.2	1-3/4	25	30	2200	600	127.5
134.1	1-7/8	25	30	2200	600	136.6
143.0	2	25	30	2200	600	145.7
152.0	2-1/8	25	30	2200	600	154.8
160.9	2-1/4	25	30	2200	600	163.9
169.9	2-3/8	25	30	2200	600	173.0
178.8	2-1/2	25	30	2200	600	182.1

## 齿轮马达 Gear Motors

Displacement 排量 ml/rev	Gear Width 齿宽 Inch 英寸	Rated Pressure 额定压力 MPa	Max Pressure 最高压力 MPa	Working Speed RPM 工作转速 转/分		Output Torque 输出扭矩 N-m
				Max 最高	Min 最低	
71.5	1	25	30	2200	600	256.3
80.5	1-1/8	25	30	2200	600	288.3
89.4	1-1/4	25	30	2200	600	320.3
98.3	1-3/8	25	30	2200	600	352.4
107.3	1-1/2	25	30	2200	600	384.4
116.2	1-5/8	25	30	2200	600	416.4
125.2	1-3/4	25	30	2200	600	448.5
134.1	1-7/8	25	30	2200	600	480.5
143.0	2	25	30	2200	600	512.5
152.0	2-1/8	25	30	2200	600	544.5
160.9	2-1/4	25	30	2200	600	576.6
169.9	2-3/8	25	30	2200	600	608.6
178.8	2-1/2	25	30	2200	600	640.6

Permco USA  
1500 Frost Road  
P. O. Box 2068  
Streetsboro, Ohio 44241  
www.permco.com  
E-mail: info@permco.com

Permco (TianJin) Hydraulic Inc., Ltd.  
泊姆克(天津)液压有限公司  
#151 Jingsi Road, Airport Economic Area  
空港经济区经四路151号  
TianJin, China PC: 300308  
中国天津 邮编300308

Tel: 022-25761959  
Fax: 022-25767035, 25761939  
www.permcotj.com  
E-mail: permco@permcotj.com  
info: technic@permcotj.com

Permco TianJin Fluidpower Mfg. Co. Ltd.  
泊姆克天津流体动力制造有限公司  
Fenghua Industrial Park 9th Avenue  
第九大街丰华工业园  
TEDA, China PC: 300457  
中国天津经济技术开发区 邮编300457